

# The untold story of StoqMA

Yupan Liu

Hebrew University of Jerusalem → ?

Available at [arXiv:2011.05733](https://arxiv.org/abs/2011.05733) and [arXiv:2010.02835](https://arxiv.org/abs/2010.02835)

Partially joint with Dorit Aharonov and Alex B. Grilo

UCL QI Theory Seminar (Virtually), Dec 2020

- 1 What is the complexity class StoqMA?
- 2 StoqMA: a distribution testing lens
- 3 Distinguishing reversible circuits
- 4 StoqMA vs. MA: the power of error reduction
- 5 Open problems

## ① What is the complexity class StoqMA?

The definition of StoqMA

What is the computational power of StoqMA

② StoqMA: a distribution testing lens

③ Distinguishing reversible circuits

④ StoqMA vs. MA: the power of error reduction

⑤ Open problems

## A "quantum" definition of MA

Consider a promise problem  $\mathcal{L} = (\mathcal{L}_{yes}, \mathcal{L}_{no}) \in \text{MA}$ , there is a verifier such that for any input  $x \in \mathcal{L}$ , a uniformly generated verification circuit  $V_x$  such that

- Yes: If  $x \in \mathcal{L}_{yes}$ ,  $\exists w$  such that  $\Pr[V_x \text{ accepts } w] \geq 2/3$ ;
- No: If  $x \in \mathcal{L}_{no}$ ,  $\forall w$ , we have  $\Pr[V_x \text{ accepts } w] \leq 1/3$ .

"Quantize" the definition: Viewed  $V_x$  as a *quantum circuit*

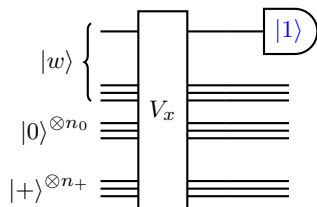

- ◇ Verification circuit using only **classical reversible gates** (i.e. Toffoli, CNOT, X).
- ◇ Measure the designed output qubit in the  $\{|0\rangle, |1\rangle\}$  **basis**.
- ◇ Ancillary qubits  $|+\rangle^{\otimes n_+}$  corresponds to randomized ancillary bits.

**Acceptance probability**  $\Pr[V_x \text{ accepts } |w\rangle] = \|\langle 1| \langle 1|_1 V_x |w\rangle |0\rangle^{\otimes n_0} |+ \rangle^{\otimes n_+} \|_2^2$

**Remark on equivalence.** The optimal witness is **classical witness** (since the matrix  $\langle \bar{0} | \langle \bar{+} | (V_x |1\rangle \langle 1|_1 V_x^\dagger) | \bar{0}\rangle | \bar{+}\rangle$  is diagonal), so it is equivalent to standard definition.

## The weird class StoqMA

Consider a promise problem  $\mathcal{L} = (\mathcal{L}_{yes}, \mathcal{L}_{no}) \in \text{StoqMA}$ , there is a verifier such that for any input  $x \in \mathcal{L}$ , a uniformly generated verification circuit  $V_x$  that measures the output qubit in the  $\{|+\rangle, |-\rangle\}$  basis such that

- Yes: If  $x \in \mathcal{L}_{yes}$ ,  $\exists |w\rangle$  such that  $\Pr[V_x \text{ accepts } |w\rangle] \geq a$ ;
- No: If  $x \in \mathcal{L}_{no}$ ,  $\forall |w\rangle$ , we have  $\Pr[V_x \text{ accepts } |w\rangle] \leq b$ ; where  $1 \geq a > b \geq 1/2$  and  $a - b \geq 1/\text{poly}(n)$ .

**Acceptance probability**  $\Pr[V_x \text{ accepts } |w\rangle] = \|\langle + |_1 V_x |w\rangle |0\rangle^{\otimes n_0} |+\rangle^{\otimes n_+}\|_2^2$

### Remarks on the weirdness

- ▶ Threshold parameters  $a, b$  cannot be replaced by some constants since *error reduction for StoqMA remains unknown* since [BBT06].
- ▶ For any non-negative witness, it is evident that  $\Pr[V_x \text{ accepts } w] \geq 1/2$ .
- ▶ Owing to Perron-Frobenius theorem, the optimal witness is **non-negative state**. W.L.O.G. we can think the witness as a **probability distribution!**

## ① What is the complexity class StoqMA?

The definition of StoqMA

What is the computational power of StoqMA

② StoqMA: a distribution testing lens

③ Distinguishing reversible circuits

④ StoqMA vs. MA: the power of error reduction

⑤ Open problems

# The computational power of StoqMA

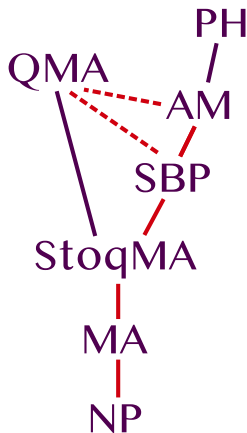

- ▶ Stoquastic (i.e. *sign problem* free) local Hamiltonian problem is StoqMA-complete [BBT06].
- ▶ Complexity classification of 2-LHP [CM13,BH14]: P, NP-complete, **StoqMA-complete**, or QMA-complete.
- ▶ StoqMA contains MA: simulating a single-qubit  $\{|0\rangle, |1\rangle\}$  basis measurement by a  $\{|+\rangle, |-\rangle\}$  basis measurement with ancillary qubits, viz.  
$$\Pr[V_x^{(+)} \text{ accepts } |w\rangle] = \frac{1}{2} + \frac{1}{2} \Pr[V_x^{(0)} \text{ accepts } |w\rangle].$$
- ▶ AM (*essentially* SBP) contains StoqMA: *Set lower bound protocol* [GS86].
- ▶  $\text{StoqMA}_1 = \text{MA}$  [BBT06,BT09].
- ▶ Under **derandomization assumptions** [KvM02,MV05], AM *collapses* to NP:  $\text{MA} = \text{StoqMA} = \text{SBP}$ .

**Q:** Is it possible to collapse the hierarchy  $\text{MA} \subseteq \text{StoqMA} \subseteq \text{SBP}$ ?

- ① What is the complexity class StoqMA?
- ② StoqMA: a distribution testing lens
- ③ Distinguishing reversible circuits
- ④ StoqMA vs. MA: the power of error reduction
- ⑤ Open problems



- 1 What is the complexity class StoqMA?
- 2 StoqMA: a distribution testing lens
  - Proving  $\text{StoqMA} \subseteq \text{MA}$  by taking samples (and failed)
  - $\text{eStoqMA} \subseteq \text{MA}$ : taking both samples and queries
  - What's the difference between  $\text{eStoqMA}$  and  $\text{StoqCMA}$ ?
- 3 Distinguishing reversible circuits
- 4 StoqMA vs. MA: the power of error reduction
- 5 Open problems

## Distribution testing in a nutshell

### Definition: Sample Access

Let  $D$  be a fixed distribution over  $\Omega$ . A sampling oracle for  $D$  is an oracle  $S_D$ : when queried,  $S_D$  returns an element  $x \in \Omega$  with probability  $D(x)$ .

### Task: Tolerant Testing

Given independent (sample) oracle accesses to  $D_0, D_1$  (both unknown), decide whether they are  $\epsilon_1$ -close or  $\epsilon_2$ -far from each other.

### Theorem: Sample Complexity Lower Bound for Tolerant Testing in $d_H^2$

(A corollary of Theorem 9 in [DKW18])

There is a **constant**  $\epsilon > 0$  such that any algorithm for tolerant testing between  $D_0$  and  $D_1$  on  $[N]$ , namely distinguishing  $d_H^2(D_0, D_1) \leq \epsilon^2/8$  from  $d_H^2(D_0, D_1) \geq \epsilon^2/2$ , **requires**  $\Omega(N/\log N)$  **samples**, where the square Hellinger distance  $d_H^2 := \frac{1}{2} \| |D_0\rangle - |D_1\rangle \|^2$ .

## Measuring non-negative states in the Hadamard basis, revisited

First (failed) attempt: proving  $\text{StoqMA} \subseteq \text{MA}$  by distribution testing

Given the state  $|0\rangle|D_0\rangle + |1\rangle|D_1\rangle := V_x |w\rangle |0\rangle^{\otimes n_0} |+\rangle^{\otimes n_+}$  (before the measurement), measure the output qubit in the  $\{|+\rangle, |-\rangle\}$  basis:

$$\begin{aligned}\| |+\rangle \langle +|_1 (|0\rangle|D_0\rangle + |1\rangle|D_1\rangle) \|_2^2 &= \frac{1}{2} \| |D_0\rangle + |D_1\rangle \|_2^2 \\ &= 1 - \frac{1}{2} \| |D_0\rangle - |D_1\rangle \|_2^2 := 1 - d_H^2(D_0, D_1),\end{aligned}$$

where  $|D_k\rangle = \sum_i \sqrt{D_k(i)} |i\rangle$  for  $k = 0, 1$  and  $\langle D_0|D_0\rangle + \langle D_1|D_1\rangle = 1$ .

- ▶ It suffices to approximate the squared Hellinger distance  $d_H^2(D_0, D_1)$  within  $1/\text{poly}(n)$  accuracy using only  $\text{poly}(n)$  sample accesses to  $D_0, D_1$ .
  - ▶ Proving MA containment by distribution testing!
- ◇ **Bad news:** This "MA containment" requires *exponentially* many samples. ☹️
- ◇ **Good news:** We probably could take advantage of other models! 😊

① What is the complexity class StoqMA?

② StoqMA: a distribution testing lens

Proving  $\text{StoqMA} \subseteq \text{MA}$  by taking samples (and failed)

**eStoqMA  $\subseteq$  MA: taking both samples and queries**

What's the difference between eStoqMA and StoqCMA?

③ Distinguishing reversible circuits

④ StoqMA vs. MA: the power of error reduction

⑤ Open problems

## From dual access model to easy witness

### Dual (query+sample) access model

- Sample access to  $D$ : Run a copy of  $V_x$  that takes  $|w\rangle$  as input, measure all qubits in the  $\{|0\rangle, |1\rangle\}$  basis, then viewed the meas. outcome as a sample.
- Query access to  $D$ : Given an index  $i$ , alg.  $Q_D$  evaluates  $D(i)$  efficiently.

**Theorem [CR14].** Approximating the total variation distance  $d_{TV}(D_0, D_1)$  with an error  $\epsilon$  requires only  $\Theta(1/\epsilon^2)$  accesses to the oracle.

### StoqMA with easy witness (eStoqMA)

- ▶ **Easy witness:** given a witness state  $|D\rangle$ , there is an algorithm  $Q_D$  such that the coordinate  $D(i)$  can be evaluated efficiently for any index  $i$ .  
e.g.  $|S\rangle = \sum_{i \in S} \frac{1}{\sqrt{|S|}} |i\rangle$  where  $S$ 's membership is *efficiently verifiable*.
- ▶ eStoqMA's definition modified from StoqMA: For yes instance  $x \in \mathcal{L}_{yes}$  where  $\mathcal{L} = (\mathcal{L}_{yes}, \mathcal{L}_{no}) \in \text{eStoqMA}$ , the witness must be easy witness.

**Remark.** Constant multiplicative error approximation of the cardinality of an efficient verifiable set is (informally) SBP-complete [Watson16, Vol20].

## eStoqMA = MA: proof sketch

**Theorem.** eStoqMA = MA.

**Proof Sketch.** Consider state  $|0\rangle|D_0\rangle + |1\rangle|D_1\rangle := V_x |w\rangle |0\rangle^{\otimes n_0} |+\rangle^{\otimes n_+}$ , then

$$\frac{\Pr[V_x \text{ accepts } |w\rangle]}{\|D_1\|_1} = \frac{\frac{1}{2} \| |D_0\rangle + |D_1\rangle \|_2^2}{\|D_1\|_1} = \mathbb{E}_{i \sim D_1 / \|D_1\|_1} \left( 1 + \frac{D_0(i)}{D_1(i)} \right)^2.$$

By Chernoff bound, an empirical estimation indicates  $1/\text{poly}(n)$  **additive error approximation of**  $\Pr[V_x \text{ accepts } |w\rangle]$ .  $\square$

**Corollary.** StoqMA<sub>1</sub>  $\subseteq$  MA.

**Proof.** It is evident that StoqMA<sub>1</sub>  $\subseteq$  eStoqMA<sub>1</sub> since the easy witness is the subset state associated with **the set that consists of all nodes that mark "good"** on the configuration graph of a ProjUSLH(0, 1/poly) instance.  $\square$

★ **Funny fact.** The proof technique of eStoqMA  $\subseteq$  MA is also used in quantum inspired classical algorithm, such as [Tang19, CGLLTW20].

① What is the complexity class StoqMA?

② StoqMA: a distribution testing lens

Proving  $\text{StoqMA} \subseteq \text{MA}$  by taking samples (and failed)

$\text{eStoqMA} \subseteq \text{MA}$ : taking both samples and queries

What's the difference between  $\text{eStoqMA}$  and  $\text{StoqCMA}$ ?

③ Distinguishing reversible circuits

④ StoqMA vs. MA: the power of error reduction

⑤ Open problems

## Remarks on StoqMA with classical witness (StoqCMA)

### Proposition (Alex B. Grilo)

$\forall 1/2 \leq b < a \leq 1$ ,  $\text{StoqCMA}(a, b) \subseteq \text{MA}(2a - 1, 2b - 1)$ .

**Proof Intuition.** Notice  $|+\rangle\langle +| = \frac{1}{2}(I + X)$ , then for any  $|\psi\rangle$ ,  
 $\langle \psi | V_x |+\rangle\langle +|_1 V_x^\dagger | \psi \rangle = \frac{1}{2} + \frac{1}{2} \langle \psi | V_x X_1 V_x^\dagger | \psi \rangle$ . □

**Corollary.**  $\text{PreciseStoqCMA} = \text{PreciseMA} = \text{NP}^{\text{PP}}$ .

**Corollary<sup>2</sup>.**  $\text{NP}^{\text{PP}} \subseteq \text{PreciseStoqMA} \subseteq \text{PSPACE}$ .

### Remarks

- ▶ Classical witness is clearly easy witness, but *the opposite is not true*.  
Since preparing  $|D\rangle$  from  $\mathcal{Q}_D$  requires the postselection.
- ▶ Classical witness is not optimal for any StoqMA verifier, e.g.  $V_x = I$ .



- ① What is the complexity class StoqMA?
- ② StoqMA: a distribution testing lens
- ③ Distinguishing reversible circuits
- ④ StoqMA vs. MA: the power of error reduction
- ⑤ Open problems

① What is the complexity class StoqMA?

② StoqMA: a distribution testing lens

③ Distinguishing reversible circuits

Reversible Circuit Distinguishability is StoqMA-complete

Soundness error reduction for StoqMA

④ StoqMA vs. MA: the power of error reduction

⑤ Open problems

## From SWAP test to Reversible Circuit Distinguishability

### SWAP test [BCWdW01]

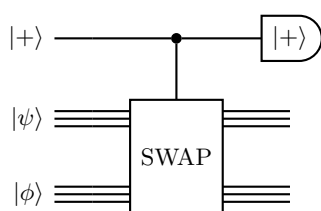

- ◇ SWAP test outputs 1 with prob.  $|\langle\psi|\phi\rangle|^2$ .
- ◇ Thinking  $|\psi\rangle \otimes |\phi\rangle$  as a witness, then SWAP test looks like a trivial StoqMA verifier with maximum accept. prob. 1 (and the optimal witness is classical).

### Reversible Circuit Distinguishability, $\text{RCD}(a, b; n_+)$

Given efficient reversible circuits  $C_0, C_1$  that utilizes ancillary states  $|0\rangle^{\otimes n_0}$  and  $|+\rangle^{\otimes n_+}$ . Let non-negative states that generates by  $C_k$  ( $k = 0, 1$ ) and  $|w\rangle$  be  $|D_k\rangle := C_k |w\rangle |0\rangle^{\otimes n_0} |+\rangle^{\otimes n_+}$ , decide whether  $\exists |w\rangle$  s.t.  $\frac{1}{2} \| |D_0\rangle - |D_1\rangle \|_2^2 \geq a$ ; or  $\forall |w\rangle$ ,  $\frac{1}{2} \| |D_0\rangle - |D_1\rangle \|_2^2 \leq b$ , where  $a - b \geq 1/\text{poly}(n)$ .

## The computational complexity of distinguishing circuits

### Theorem

Reversible Circuit Distinguishability, viz.  $\text{RCD}(\cdot, \cdot; \text{poly})$ , is StoqMA-complete.

- ▶ **Theorem [JWZ03].** Quantum Circuit Distinguishability is QMA-complete.
- ▶ **Theorem [Jor14].** Reversible Circuit Distinguishability (without randomized ancillary bit), viz.  $\text{RCD}(\cdot, \cdot; 0)$ , is NP-complete.

★  $\text{RCD}(\cdot, \cdot; \text{poly})$  seems MA-complete but it is actually StoqMA-complete!

### Proposition 1

Exact Reversible Circuit Dist., viz.  $\text{RCD}(a, 0; \text{poly})$ , is NP-complete.

**Corollary.** StoqMA with perfect soundness is contained in NP.

- ▶ **Theorem [FGMSZ89]** Arthur-Merlin games with perfect soundness  $\subseteq$  NP.
- ▶ **Theorem [Tan10]** Exact Quantum Circuit Distinguishability is NQP-complete, namely QMA with perfect soundness.

### Proposition 2

RCD without randomized ancillary bit, viz.  $\text{RCD}(\cdot, \cdot; 0)$ , is NP-complete.

**Corollary (Simplified proof of [Jor14]).**  $\text{RCD}(\cdot, \cdot; 0)$  is NP-complete.

## Reversible Circuit Distinguishability is StoqMA-complete: proof sketch

For  $k = 0, 1$ , let  $|D_k\rangle := C_k |w\rangle |0\rangle^{\otimes n_0} |+\rangle^{\otimes n_+}$ , then:

- ▶  $\text{RCD}(a, b; \text{poly})$  is contained in  $\text{StoqMA}(1 - \frac{a}{2}, 1 - \frac{b}{2})$ .

◊ Dash line:

$$\frac{1}{\sqrt{2}} |0\rangle |D_0\rangle + \frac{1}{\sqrt{2}} |1\rangle |D_1\rangle.$$

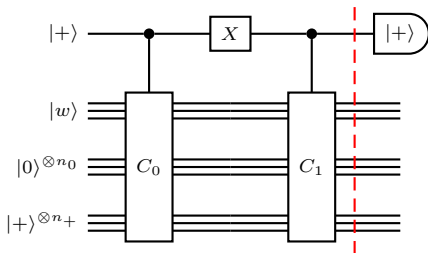

- ▶  $\text{RCD}(a, b; \text{poly})$  is hard for  $\text{StoqMA}(1 - \frac{a}{2}, 1 - \frac{b}{2})$ .

◊ Set  $C_0 := V_x^\dagger X_1 V_x$  and  $C_1 := I$ .

◊ Let  $M := \langle \bar{0} | \langle \bar{+} | V_x^\dagger X_1 V_x | \bar{0} \rangle | \bar{+} \rangle$ , then  $\Pr[V_x \text{ accepts } |w\rangle] = \frac{1}{2} + \frac{1}{2} \lambda_{\max}(M)$ .

**Remark.** This observation went back to (weak) error reduction for QMA [KSV02].

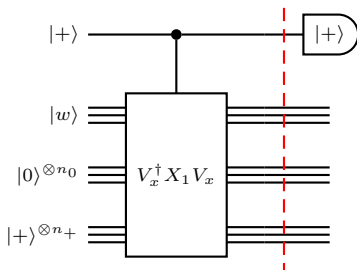

① What is the complexity class StoqMA?

② StoqMA: a distribution testing lens

③ Distinguishing reversible circuits

Reversible Circuit Distinguishability is StoqMA-complete

Soundness error reduction for StoqMA

④ StoqMA vs. MA: the power of error reduction

⑤ Open problems

# Soundness error reduction for StoqMA

## Theorem (AND-type repetition procedure of StoqMA)

For any  $l = \text{poly}(n)$ ,  $\text{StoqMA}\left(\frac{1}{2} + \frac{a}{2}, \frac{1}{2} + \frac{b}{2}\right) \subseteq \text{StoqMA}\left(\frac{1}{2} + \frac{a^{l(n)}}{2}, \frac{1}{2} + \frac{b^{l(n)}}{2}\right)$ .

**Corollary.**  $\forall 1 - a \geq \frac{1}{\text{poly}(n)}, l = \text{poly}(n), \text{StoqMA}(1, a) \subseteq \text{StoqMA}(1, 2^{-l(n)})$ .

## Proof Sketch

Recall that  $\Pr[V_x \text{ accepts } |w\rangle] = \frac{1}{2} + \frac{1}{2}\lambda_{\max}(M)$  where  $M = \langle \bar{0} | \langle \bar{+} | V_x^\dagger X_1 V_x | \bar{0} \rangle | \bar{+} \rangle$ .

Let us take the tensor product (i.e. "conjunction" or "AND") now:

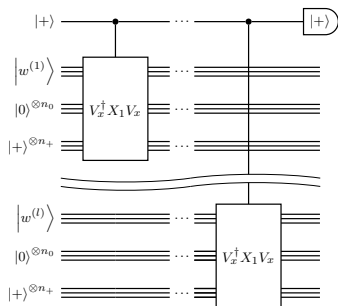

◇ Maximum acceptance probability:

$$\Pr[V'_x \text{ accepts } w^{(1)} \otimes \dots \otimes w^{(l)}]$$

$$= \frac{1}{2} + \frac{1}{2}\lambda_{\max}(M^{\otimes l})$$

$$= \frac{1}{2} + \frac{1}{2}(\lambda_{\max}(M))^l$$

◇ **Yes case:** ✓

◇ **No case:** Entangled witness will not increase the maximum acceptance probability. □

- ① What is the complexity class StoqMA?
- ② StoqMA: a distribution testing lens
- ③ Distinguishing reversible circuits
- ④ StoqMA vs. MA: the power of error reduction
- ⑤ Open problems



① What is the complexity class StoqMA?

② StoqMA: a distribution testing lens

③ Distinguishing reversible circuits

④ StoqMA vs. MA: the power of error reduction

Why error reduction is important for StoqMA?

$\text{ProjUSLH}(\text{negl}, 1/\text{poly})$  is  $\text{StoqMA}_{1-\text{negl}}$ -complete

Proof Sketch:  $\text{ProjUSLH}(\text{negl}, 1/\text{poly}) \in \text{MA}_{1-\text{negl}'}$

⑤ Open problems

## Error reduction for StoqMA implies $\text{StoqMA} = \text{MA}$

### Theorem [AGL20]

(Completeness) error reduction for StoqMA implies  $\text{StoqMA} \subseteq \text{MA}$ .

Namely,  $\text{StoqMA}(1 - 1/p_1(n), 1 - 1/p_2(n)) \subseteq \text{MA}$ , where  $p_1$  is a *super-polynomial* of  $n$  and  $p_2$  is a polynomial of  $n$ .

### Proof Intuition

Notice [BBT06, BT09] essentially proves  $\text{StoqMA}_1 \subseteq \text{MA}_1$ . It seems plausible to make it *robust*, namely  $\text{StoqMA}_{1-\epsilon} \subseteq \text{MA}_{1-\epsilon'}$  where  $\epsilon$  and  $\epsilon'$  are negligible.

MA containment Given a configuration graph  $G(H) = (V_H, E_H)$  that each node is marked either "good" or "bad", there is a R.W. that starts at node  $v \in V_H$  such that

- Yes:  $\exists v$  s.t. R.W. will not reach any "bad" node in *any poly(n) steps w.h.p.*
- No:  $\forall v$ , R.W. will reach "bad" node in  $p(n)$  steps where  $p$  is *some poly.* w.h.p.

(See Sergey Bravyi's tutorial for more details.)

★ To make this R.W. "robust", we need **the probabilistic method!**

- ▶ Interestingly, *the probabilistic method and completeness error reduction* are also used in proof of  $\text{MA} \subseteq \text{MA}_1$  [FGMSZ89]!

① What is the complexity class StoqMA?

② StoqMA: a distribution testing lens

③ Distinguishing reversible circuits

④ StoqMA vs. MA: the power of error reduction

Why error reduction is important for StoqMA?

**ProjUSLH(negl, 1/poly) is StoqMA<sub>1-negl</sub>-complete**

Proof Sketch: ProjUSLH(negl, 1/poly)  $\in$  MA<sub>1-negl'</sub>

⑤ Open problems

## ProjUSLH: a $\text{StoqMA}_{1-\text{negl}}$ -complete problem

Definition: Projection Uniform Stoquastic  $k$ -LHP ( $\text{ProjUSLH}(\alpha, \beta)$ )

Given a  $k$ -local stoquastic (i.e. all off-diagonal elements of  $H_i$  are non-positive) Hamiltonian  $H = \frac{1}{m} \sum_{i=1}^m H_i$ . This Hamiltonian is *projection uniform* if  $\forall i$ ,  $H_i = I - P_i$  where the ground space projector  $P_i = \sum_j |S_{i,j}\rangle \langle S_{i,j}|$  for disjoint subsets  $S_{i,j} \subseteq \{0, 1\}^k$ . Decide whether

- Yes:  $\exists$  a state  $|\psi\rangle$  s.t.  $\langle \psi | H | \psi \rangle \leq \epsilon_1(n)$ ;
- No:  $\forall$  state  $|\psi\rangle$ ,  $\langle \psi | H | \psi \rangle \geq \epsilon_2(n)$ ;

where  $0 \leq \epsilon_1(n) < \epsilon_2(n) \leq 1$ .

◇ Frustration: A Hamiltonian  $H$  is  $\epsilon$ -frustrated if its ground energy  $\min_{|\psi\rangle} \langle \psi | H | \psi \rangle$  is at least  $\epsilon$ .

Theorem [BBT06, AGL20]

$k$ -ProjUSLH( $\text{negl}, 1/\text{poly}$ ) is  $\text{StoqMA}_{1-\text{negl}}$ -complete.

## ProjUSLH: a StoqMA<sub>1-negl</sub>-complete problem (Cont.)

### Definition: Configuration Graph

The configuration graph  $G(H) = (V_H, E_H)$  is defined by:

$\forall s, t \in \{0,1\}^n, \exists \text{ edge } (s,t) \in E_H \text{ iff } \langle s|P_i \otimes I|t \rangle > 0.$

A node  $s \in V_H$  is marked by "bad", i.e.  $s \in B_i(S)$ , if  $\langle s|P_i \otimes I|s \rangle = 0$ ;

Otherwise this node is marked by "good".

◇ Example: A 2-ProjUSLH instance  $H = H_1 + H_2 + H_3$  defined on a 4-node line.

Ground space projectors:

$$P_1 = (|00\rangle + |11\rangle)(\langle 00| + \langle 11|)_{1,2},$$

$$P_2 = (|00\rangle + |11\rangle)(\langle 00| + \langle 11|)_{2,3} + (|01\rangle + |10\rangle)(\langle 01| + \langle 10|)_{2,3},$$

$$P_3 = (|00\rangle + |11\rangle)(\langle 00| + \langle 11|)_{3,4}.$$

Consider  $|S\rangle$  where  $S = \{0000, 1100, 0110, 0011, 1111\}$ .

Frustration is contributed by a "bad" node: 0110, and nodes that connects to  $S$ : 1010, 1001, 0101.

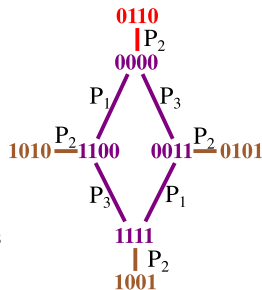

① What is the complexity class StoqMA?

② StoqMA: a distribution testing lens

③ Distinguishing reversible circuits

④ StoqMA vs. MA: the power of error reduction

Why error reduction is important for StoqMA?

$\text{ProjUSLH}(\text{negl}, 1/\text{poly})$  is  $\text{StoqMA}_{1-\text{negl}}$ -complete

**Proof Sketch:**  $\text{ProjUSLH}(\text{negl}, 1/\text{poly}) \in \text{MA}_{1-\text{negl}}$

⑤ Open problems

# ProjUSLH(negl, 1/poly) is in MA: proof sketch (Completeness)

- ① Well-approximated subset state exists:

$$\langle S|H|S \rangle \leq 1/f(n)$$

$$\Rightarrow \langle S'|H|S' \rangle \leq m/f(n),$$

where  $S'$  contains only good strings.

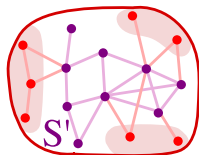

- ② Small-frustration state implies small-size boundary:

$$\langle S'|H|S' \rangle \leq 1/h(n)$$

$$\Rightarrow |\partial S'|/|S'| \leq 2^k m/h(n).$$

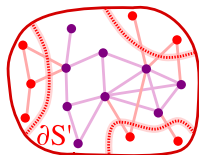

- ③ Any subset with a small-size boundary has a good starting point:

$$\frac{|\partial S'|}{|S'|} \leq \frac{1}{p_1(n)} \Rightarrow \mathbb{E}_{v \sim \pi_S} \left[ \Pr \left[ \bigwedge_{l=1}^T X_v^{(l)} \in S' \right] \right] \geq 1 - \frac{1}{p_2(n)} \text{ where } p_2 \propto \frac{p_1}{T}.$$

Ref. [ST08, GT12] [Expectation bounds on remained probability](#)

★ There is a starting point  $v$  (viz. *classical witness*) such that any  $T(n)$ -step B.T. random walk remained in  $S'$  w.h.p. where  $T(n)$  is a [super-polynomial](#).

- ① What is the complexity class StoqMA?
- ② StoqMA: a distribution testing lens
- ③ Distinguishing reversible circuits
- ④ StoqMA vs. MA: the power of error reduction
- ⑤ Open problems



## Conclusions and open problems

### Take-home messages

- 1 StoqMA with easy witness (eStoqMA) is contained in MA, which simply infers  $\text{StoqMA}_1 \subseteq \text{MA}$ .
- 2 Reversible Circuit Distinguishability is StoqMA-complete (instead of MA-complete as expected!). The exact variant is NP-complete, which signifies that StoqMA with perfect soundness is contained in NP.
- 3 (Completeness) error reduction (still open!) for StoqMA implies  $\text{StoqMA} = \text{MA}$ ; we know how to do soundness error reduction for StoqMA.

### Open problems

- 1 StoqMA vs. MA and SBP vs. MA.
- 2 (Completeness) error reduction for StoqMA.
- 3 StoqMA with exponentially small gap (PreciseStoqMA).
- 4 The computational power of QMA with perfect soundness (i.e. NQP).
- 5 More StoqMA-complete problems, such as Stoquastic CLDM.

# Thank you!

Slides are available on [shorturl.at/cmHX1](https://shorturl.at/cmHX1).